

*EV3 Print3robot*

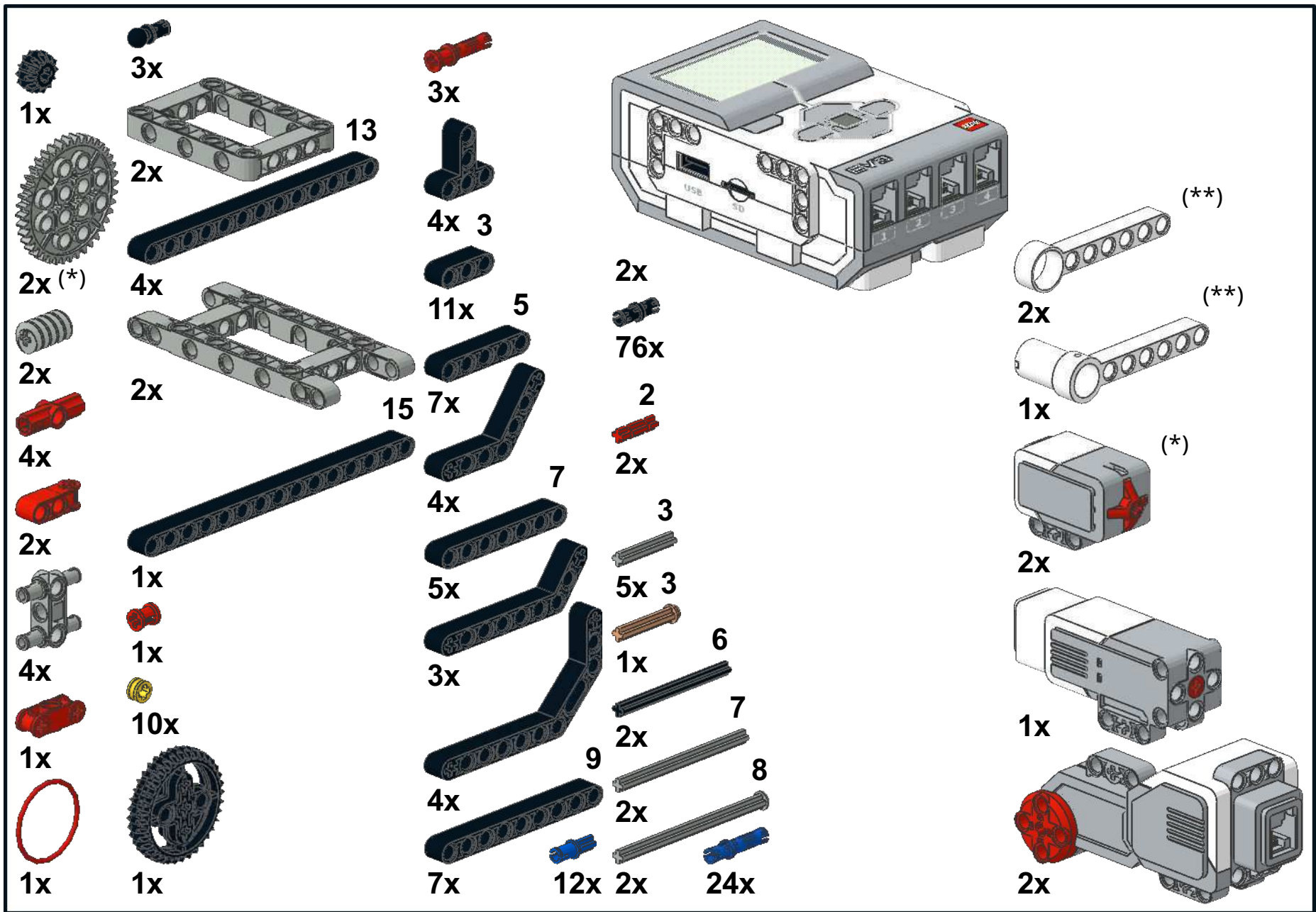

(\*) not included in the ev3 home edition.

(\*\*) see <http://www.thingiverse.com/thing:409421> for the pen holder

# 1

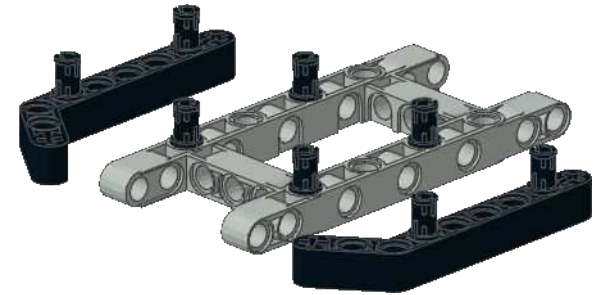
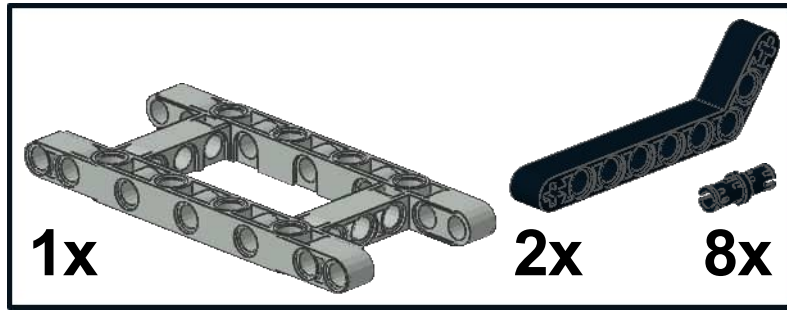

# 2

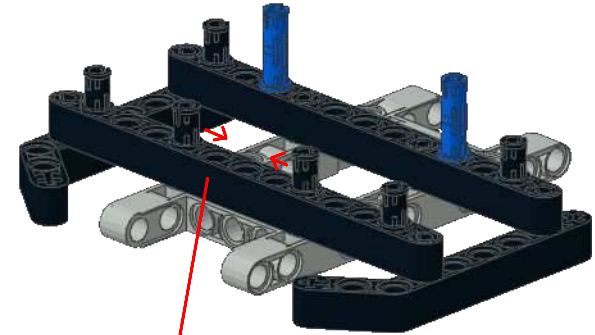
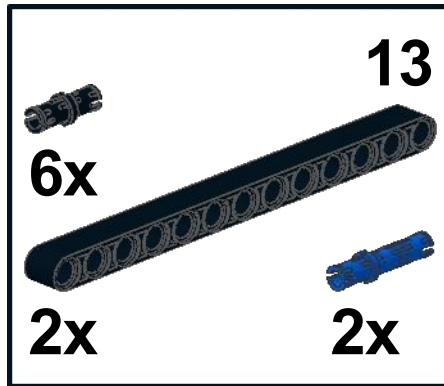

(shift black pins 1 lego unit toward the center)

# 3

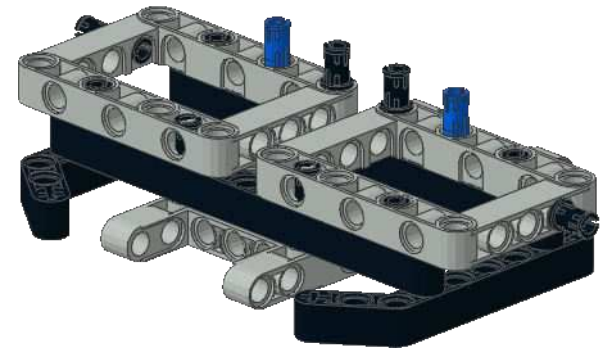
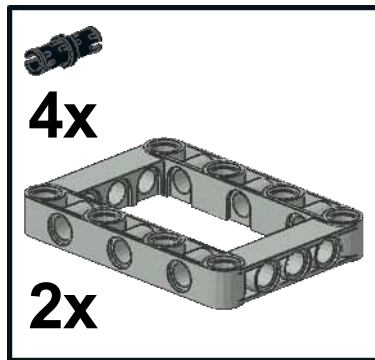

4

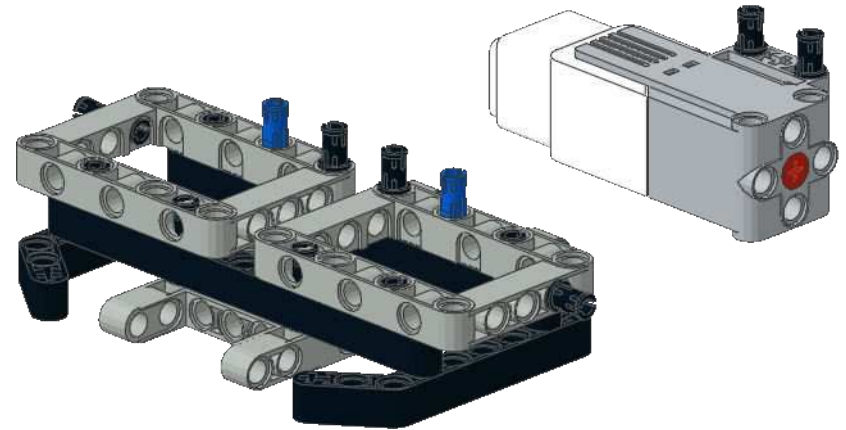
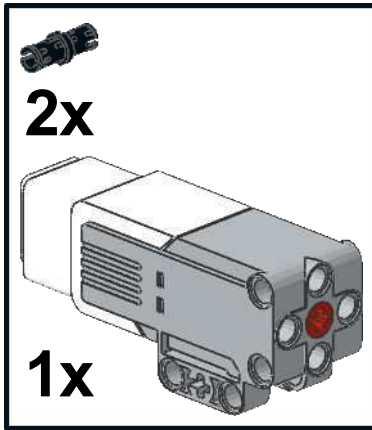

5

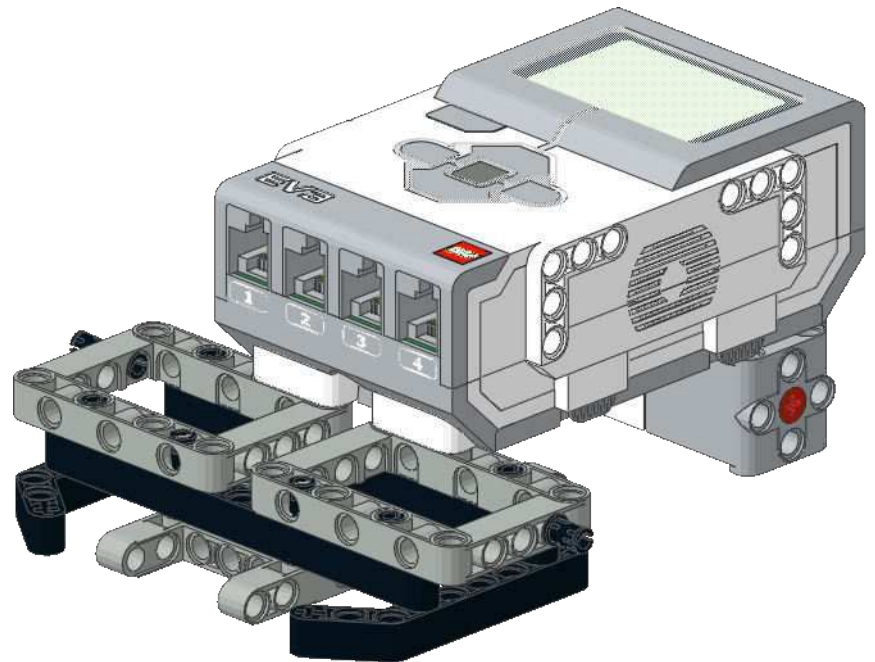
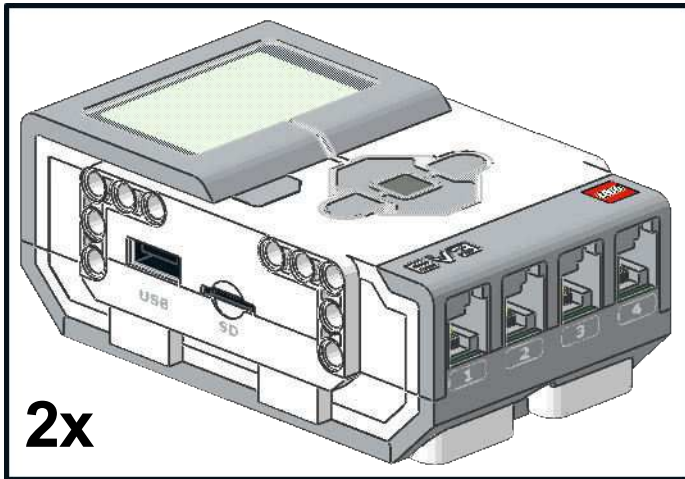

6

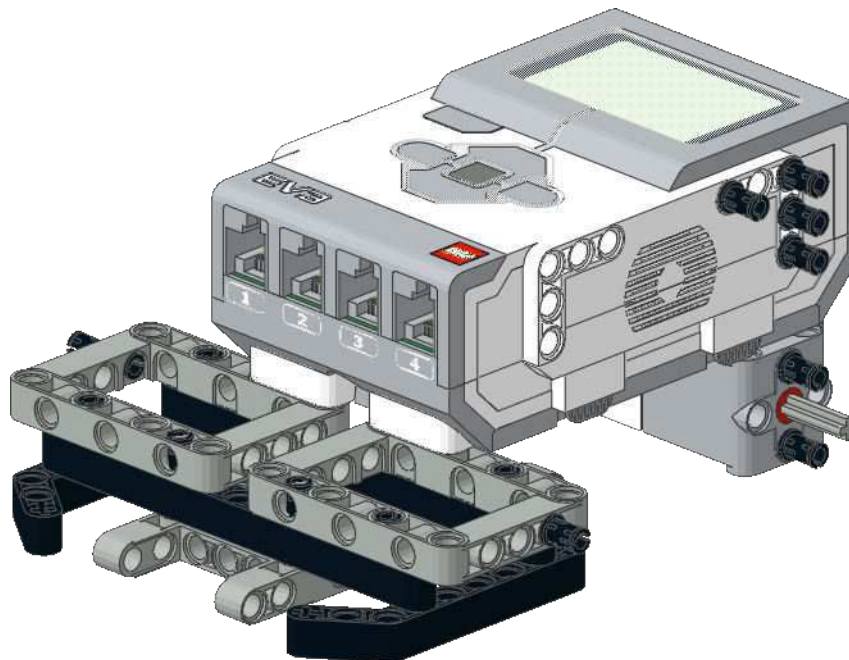
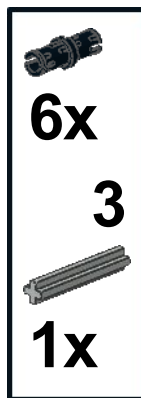

7

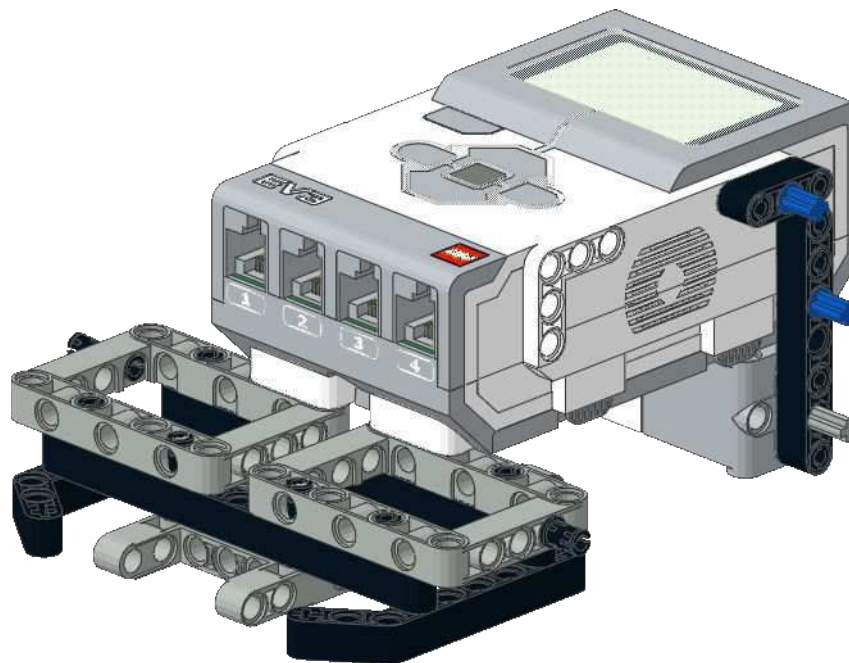
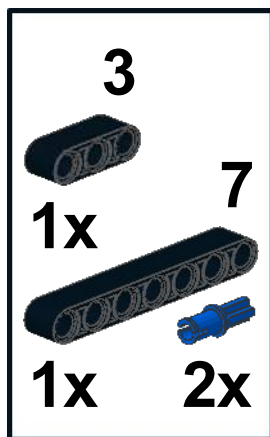

8

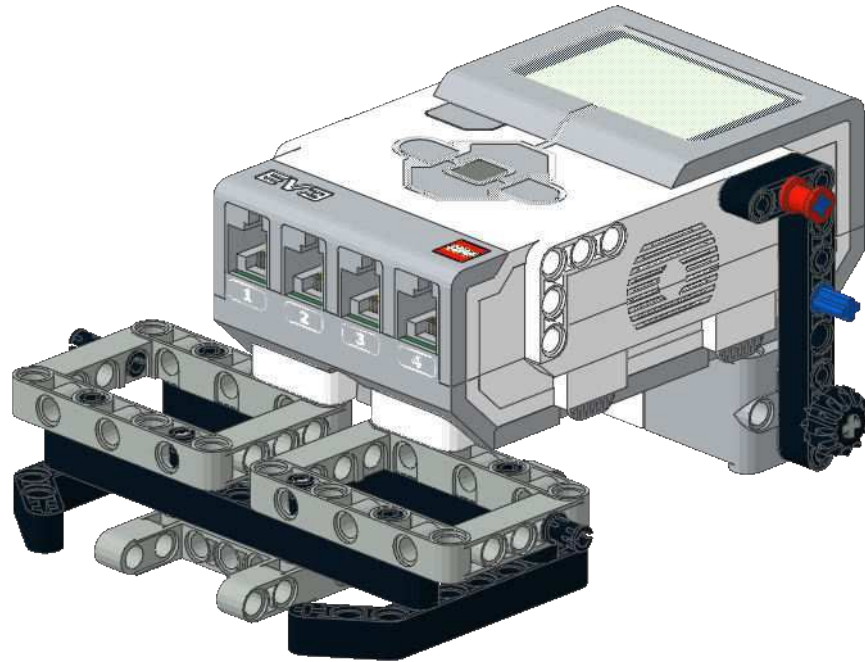
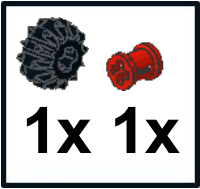

9

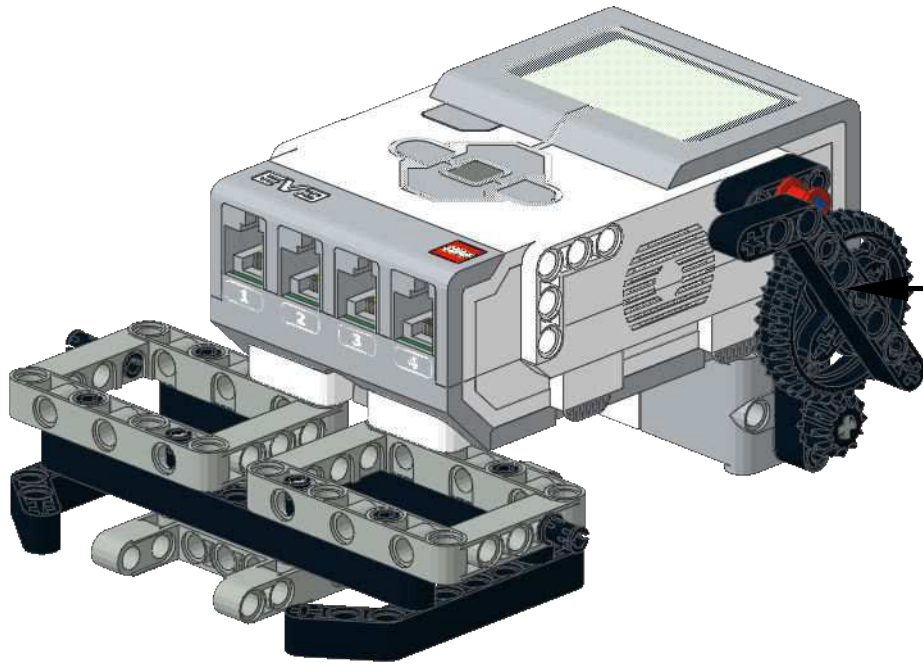

1

1x 2x

2

1x 1x

The parts list is contained within a yellow rectangular box. It is divided into two sections, labeled '1' and '2'. Section 1 shows a large gear and two small pins. Section 2 shows an L-shaped Technic beam and one small pin. Below the parts list, there are two sub-diagrams: the first shows a gear connected to a beam, and the second shows a gear connected to a beam with a pin inserted into the beam's hole.

10

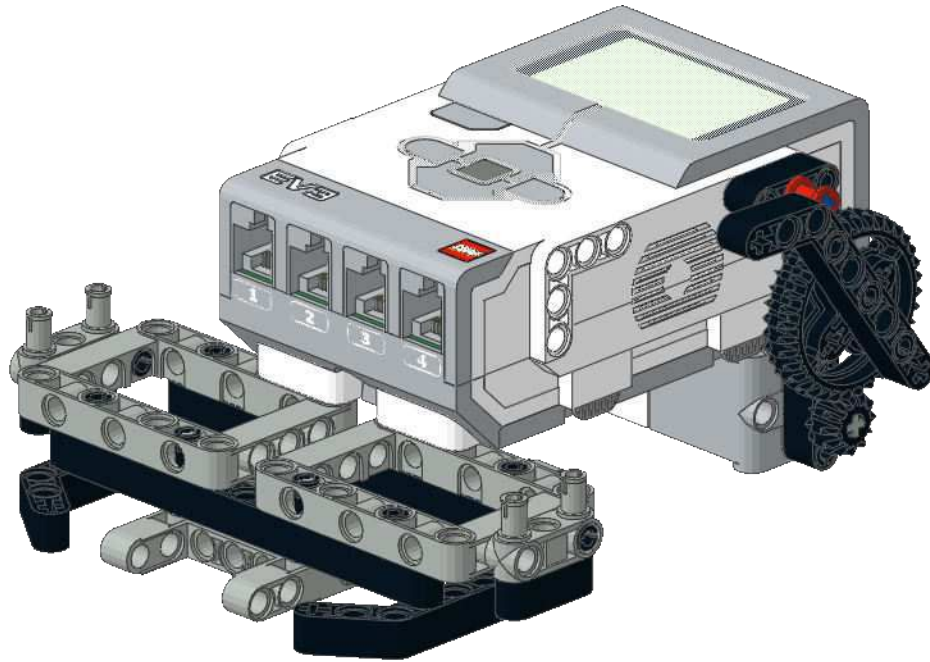
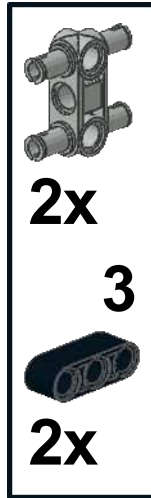

11

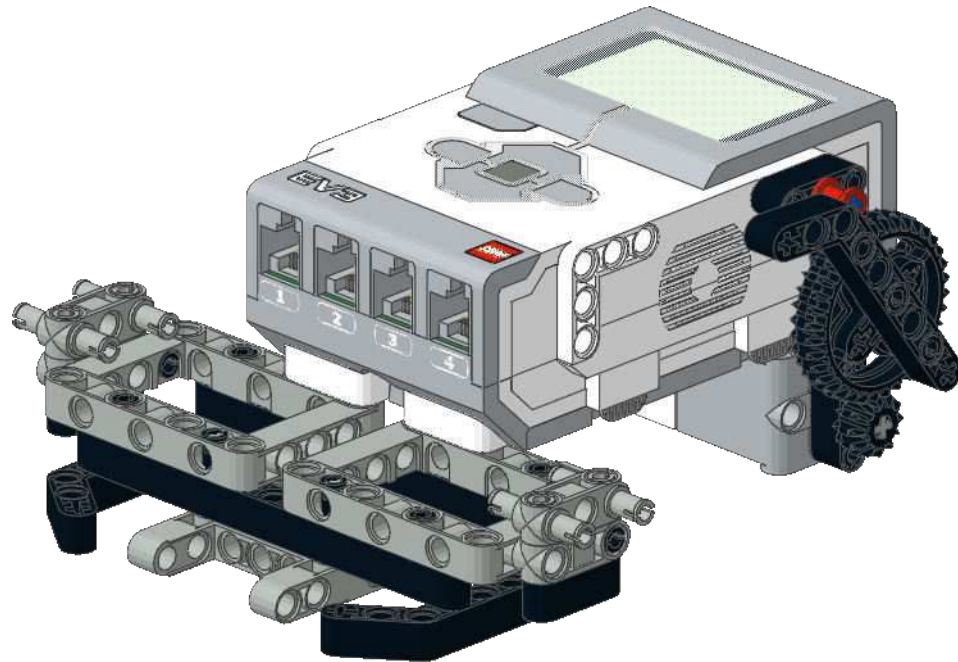
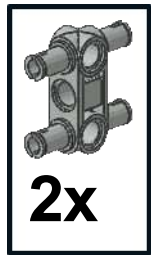



# 12

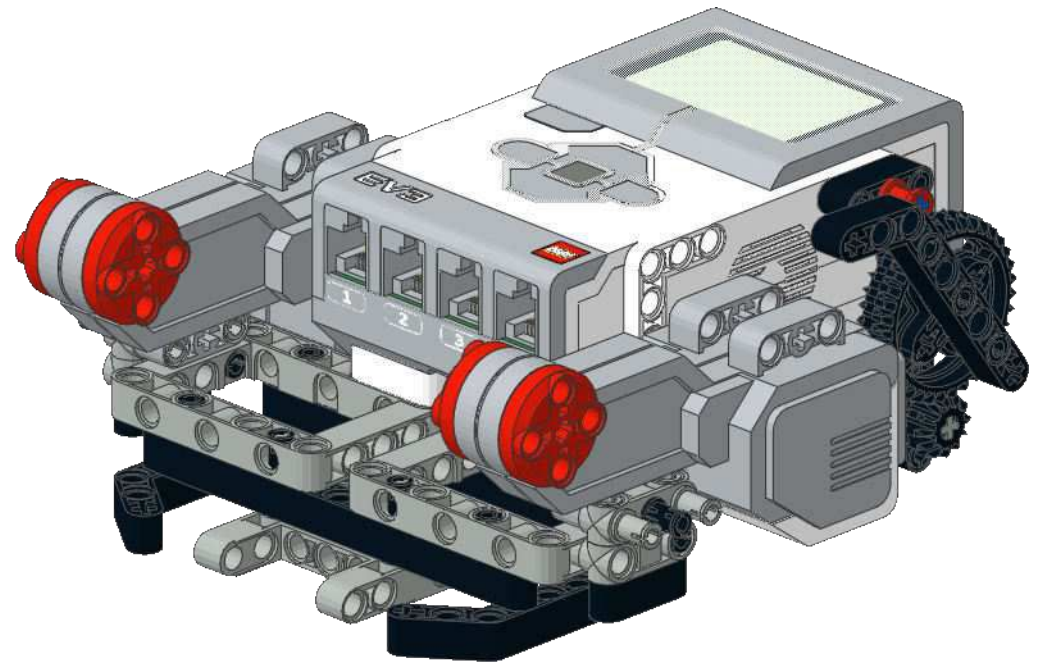
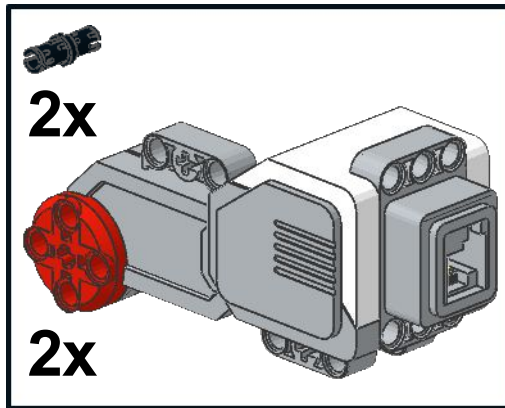

# 13

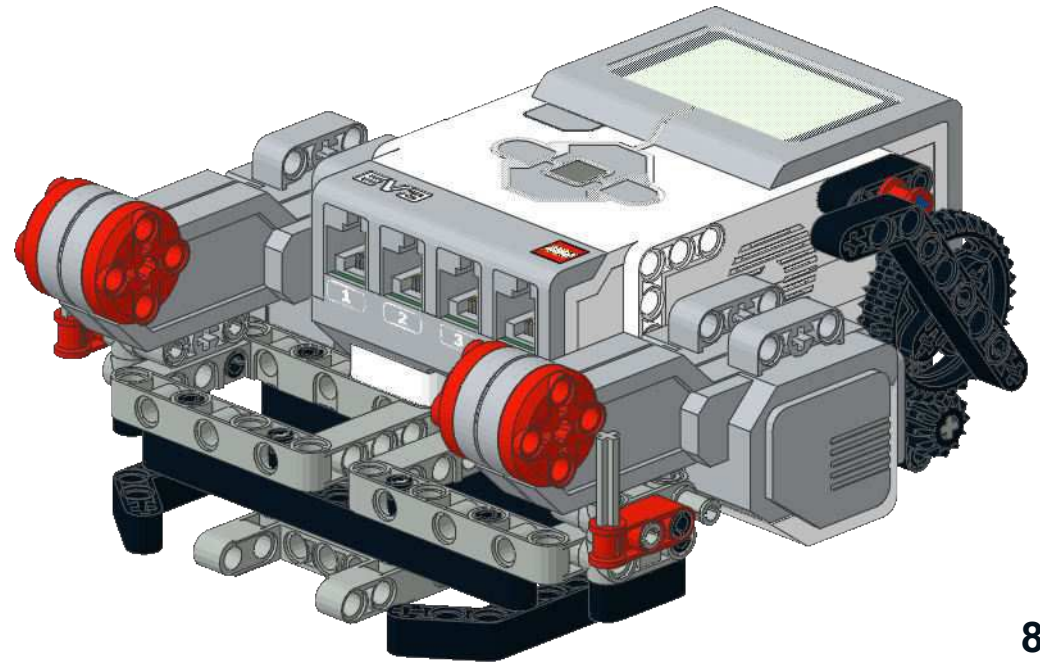
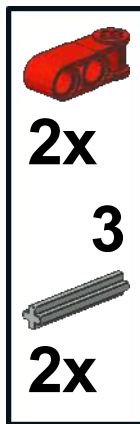

# 14

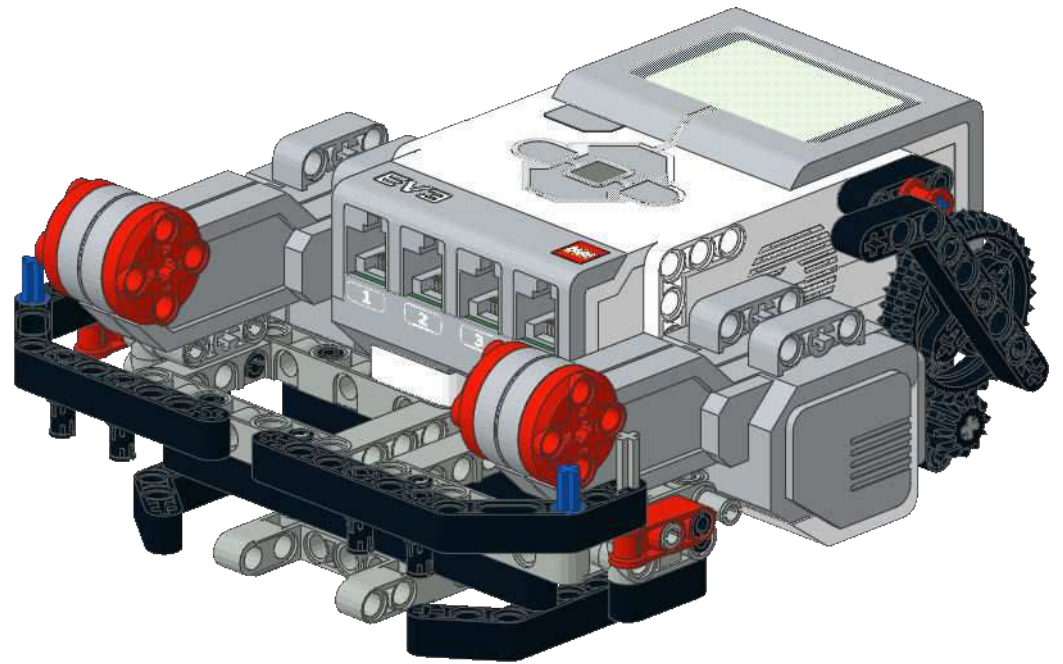
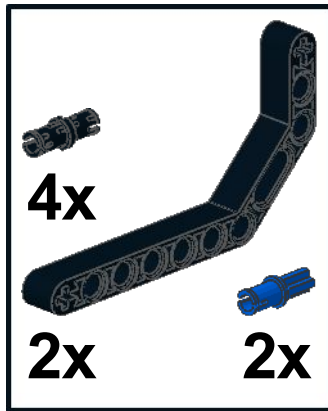

# 15

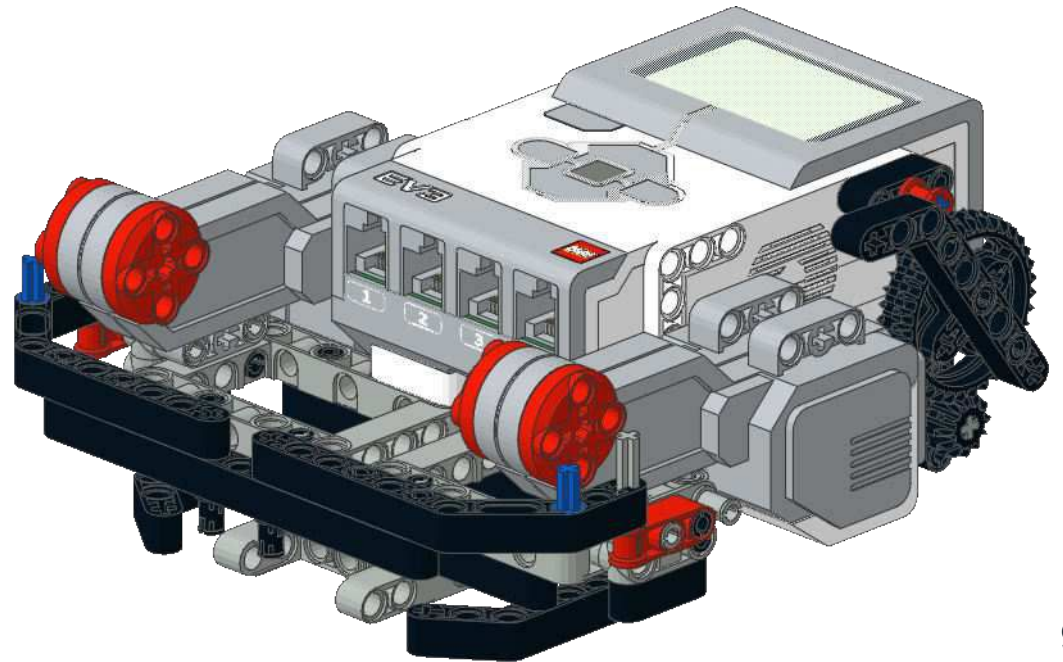
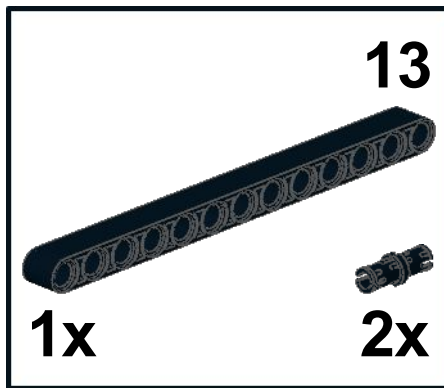

# 16

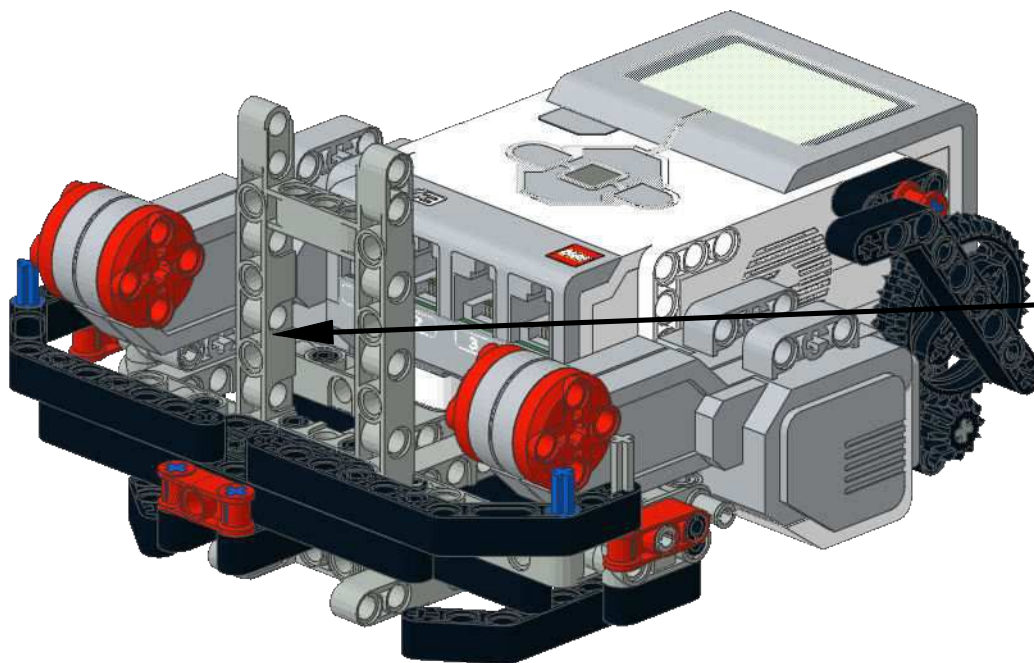
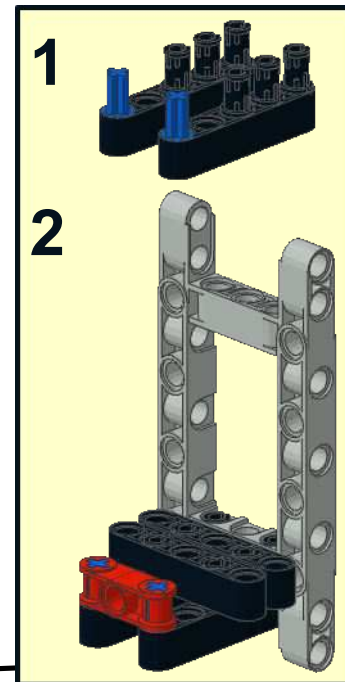
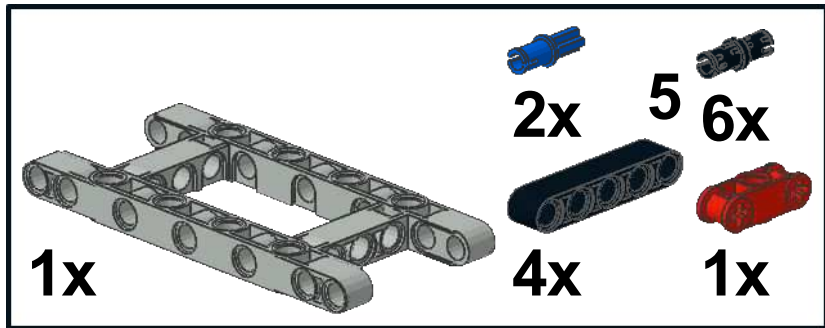

17

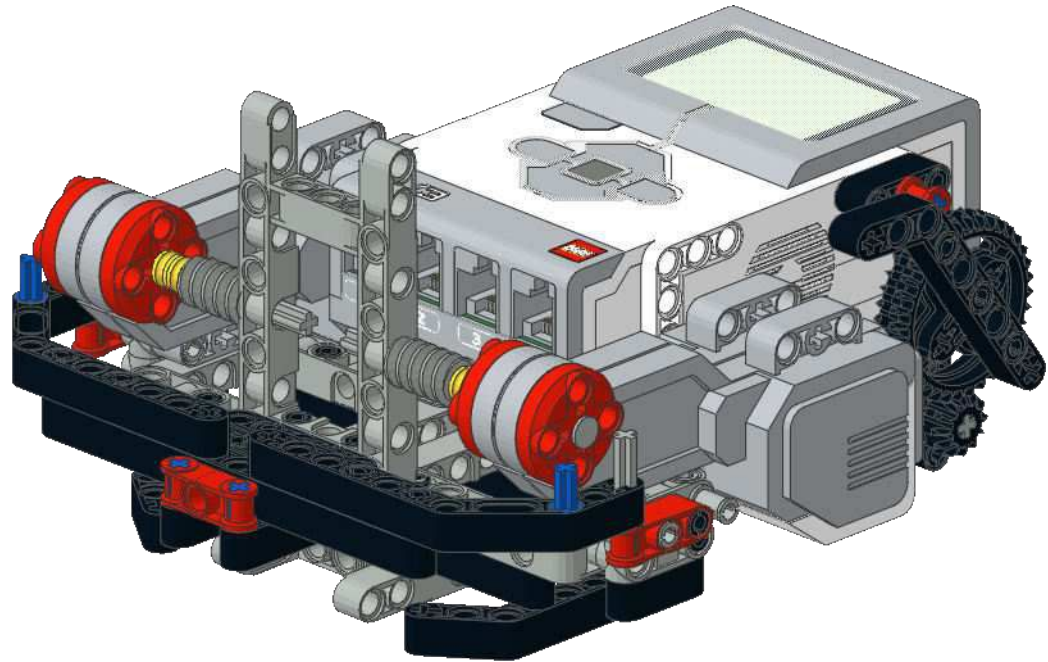
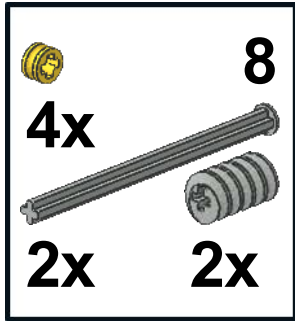

# 18

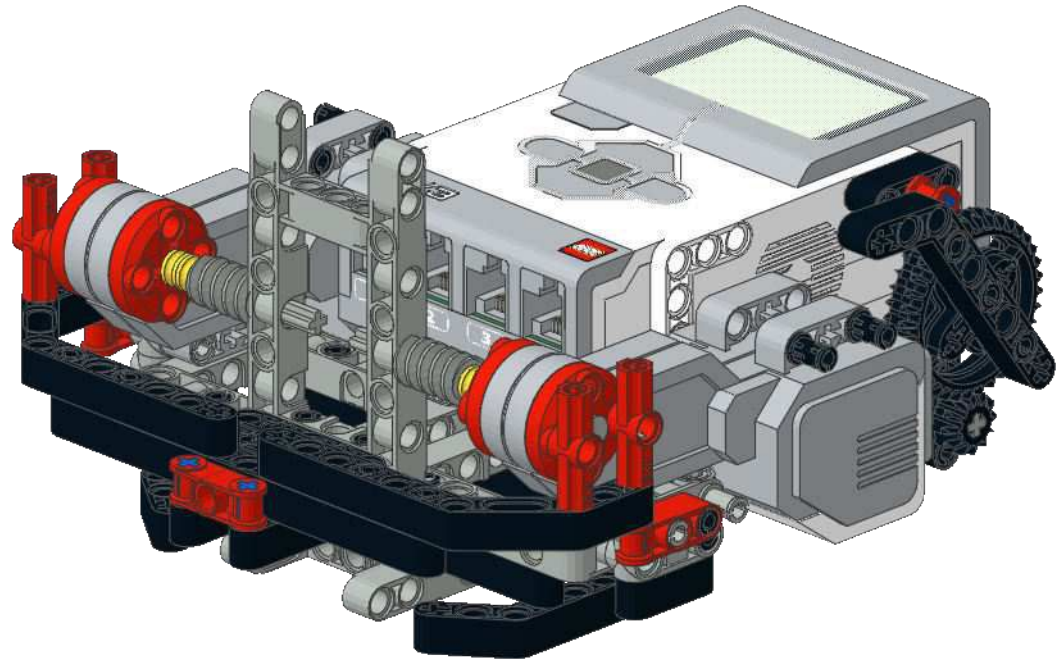

# 19

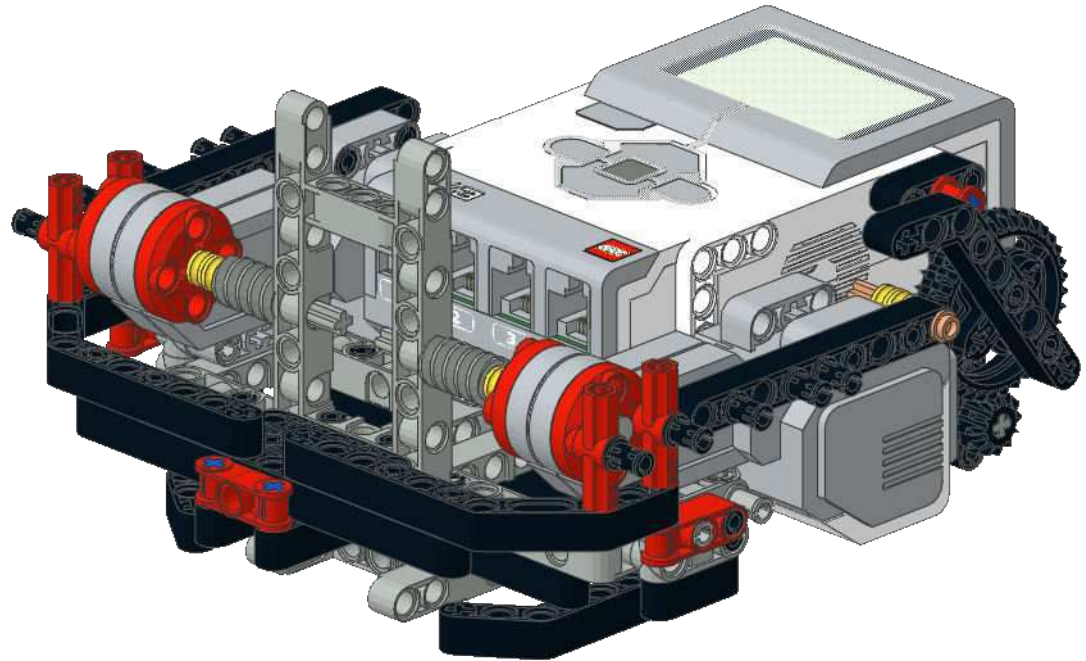
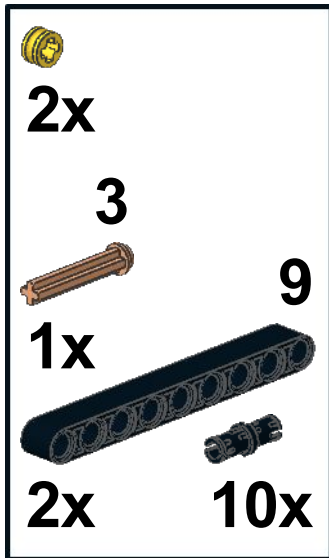

20

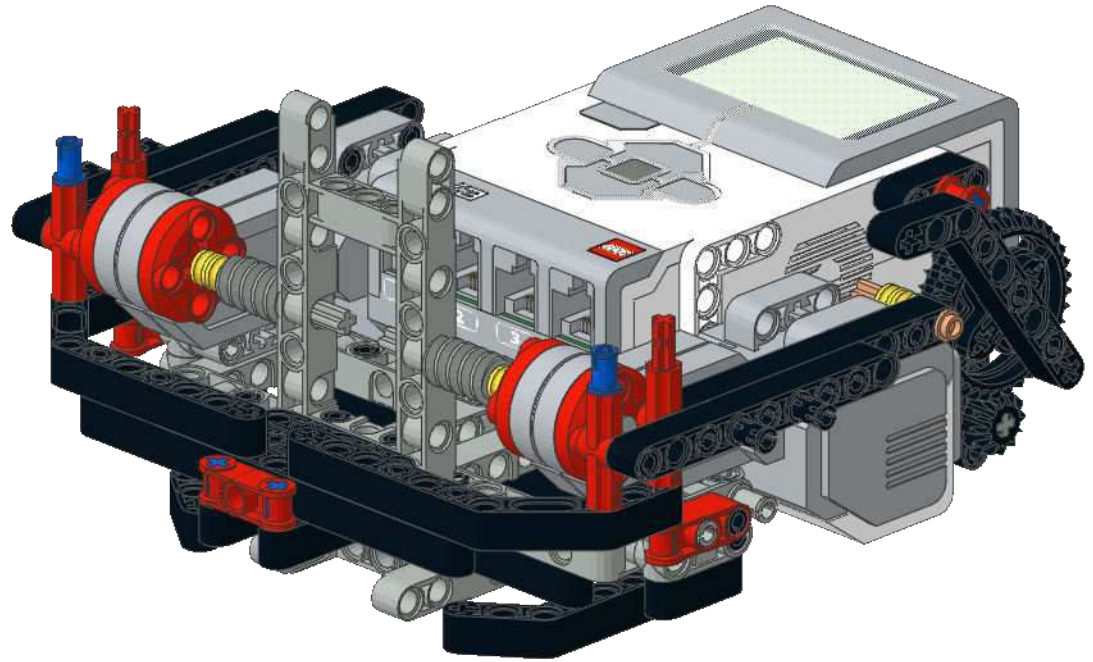
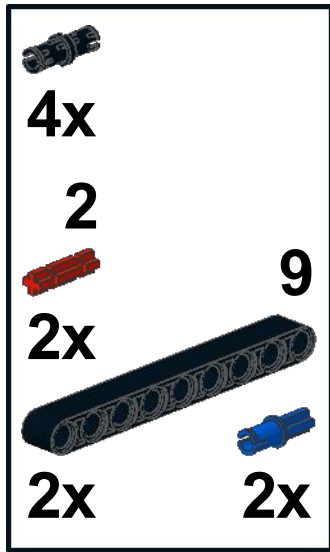

21

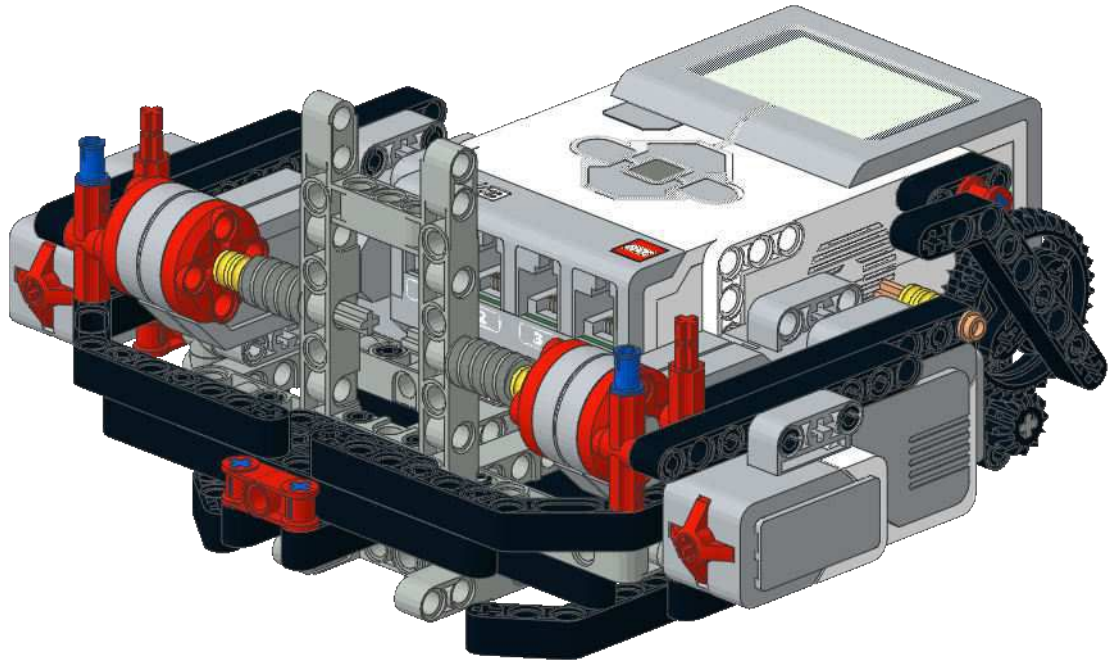
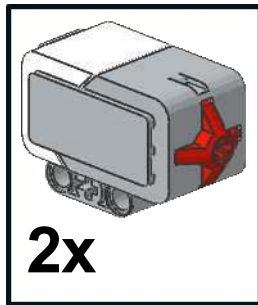

1

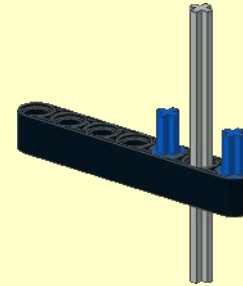
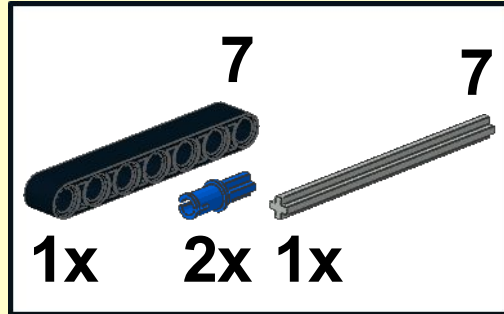

2

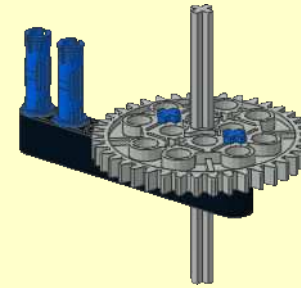
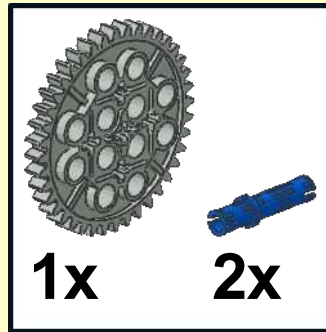

3

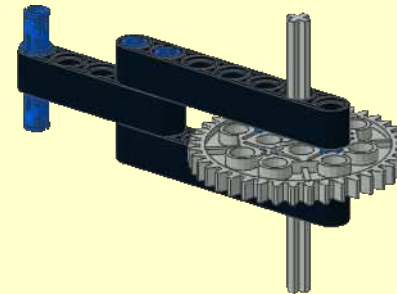
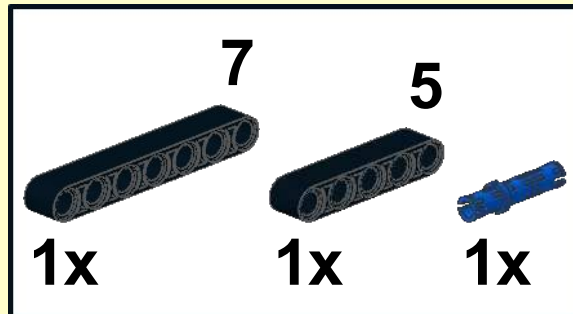

4

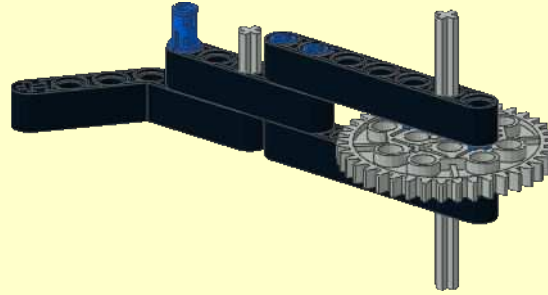
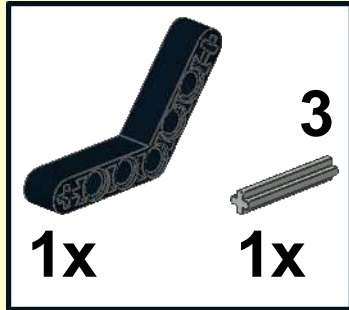

5

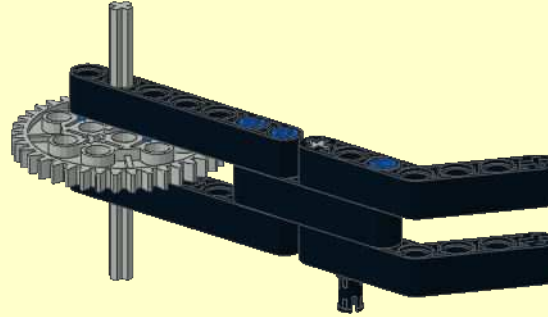
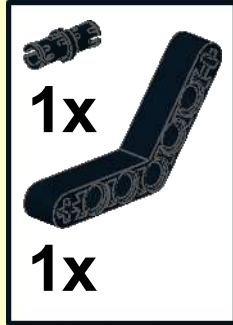

6

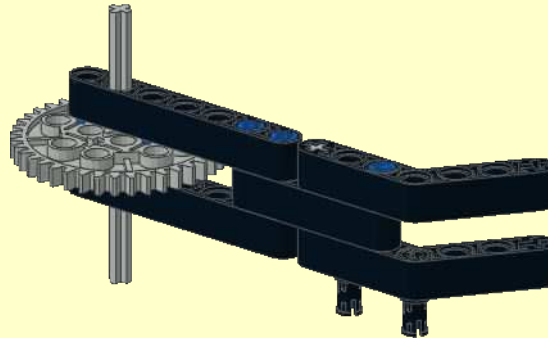



7

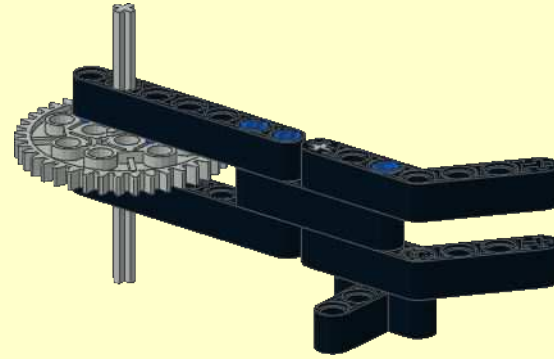

8

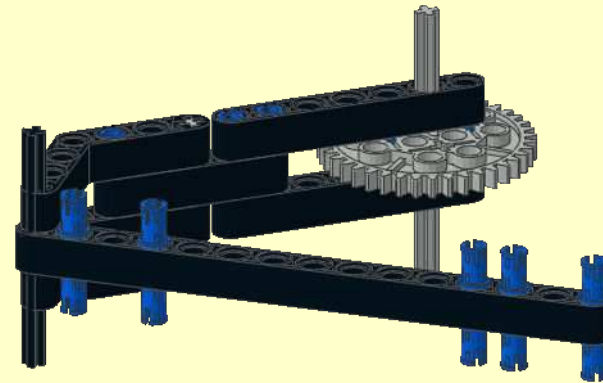
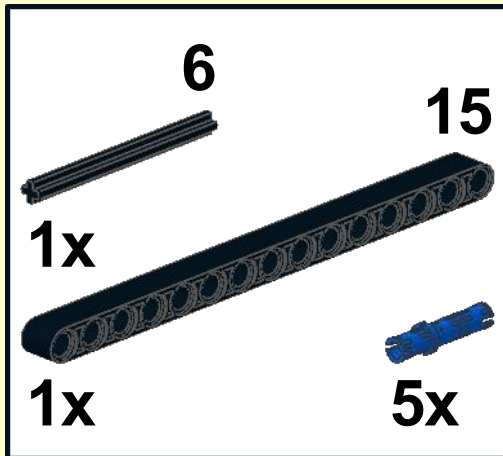

9

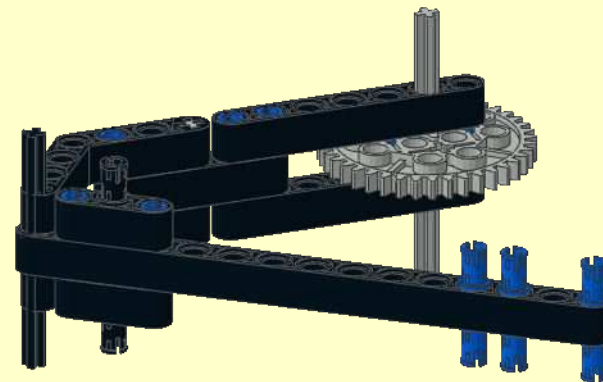

10

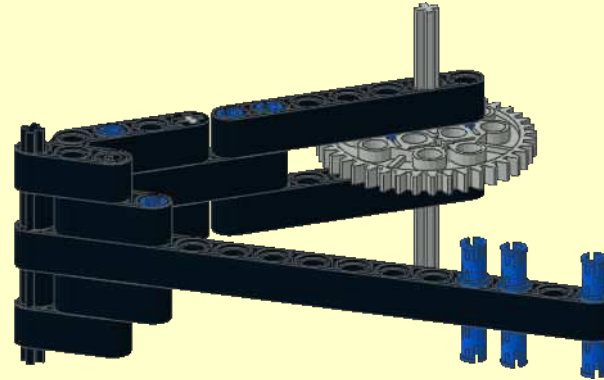

11

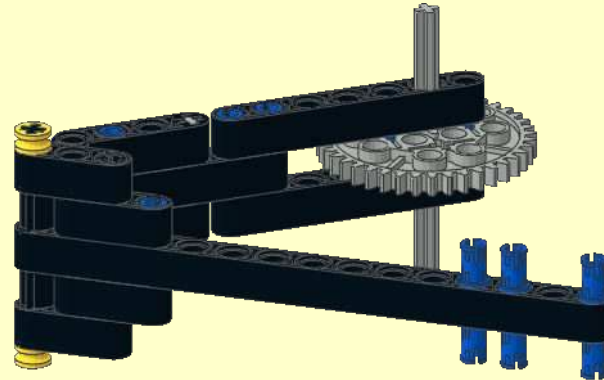

22

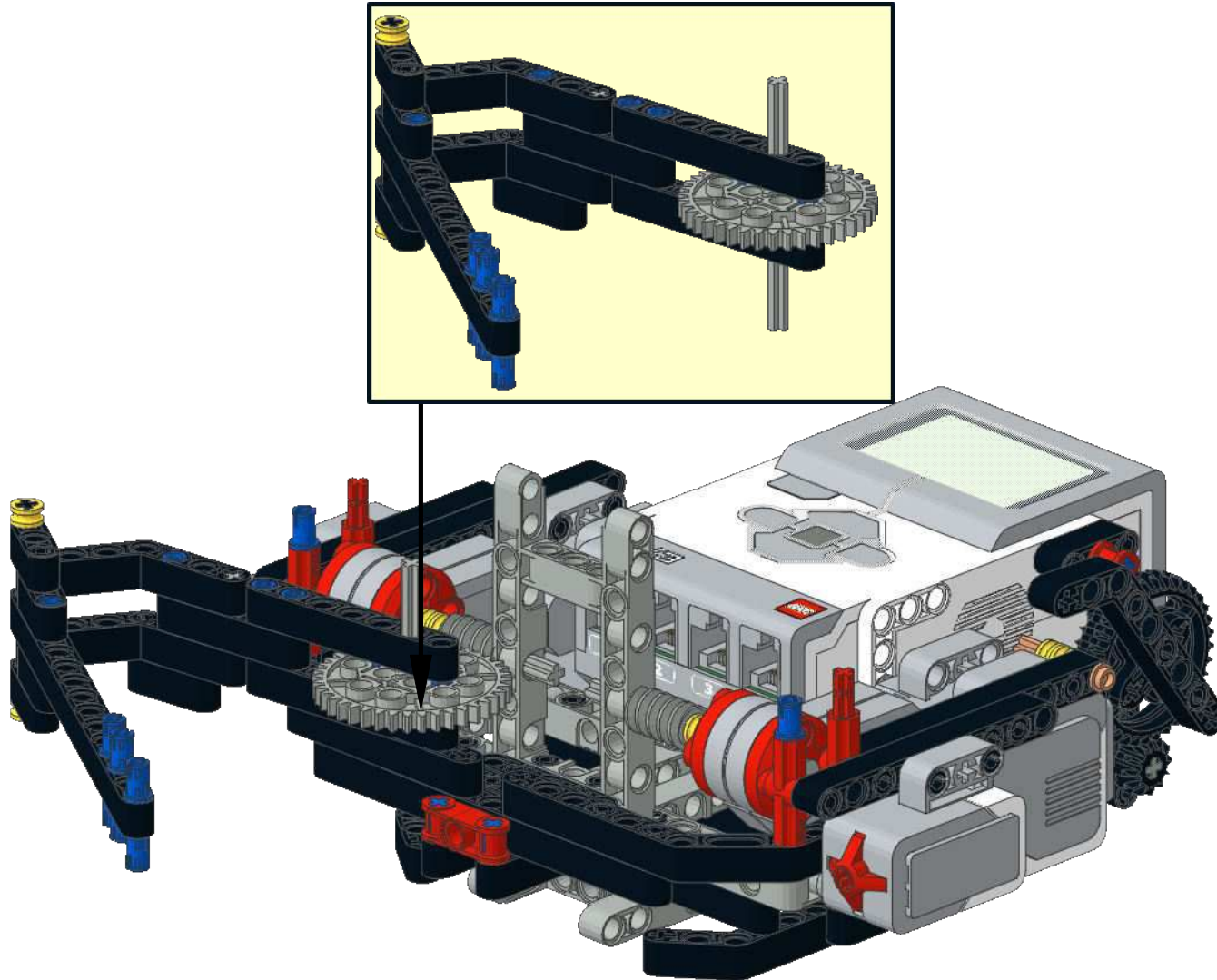

1

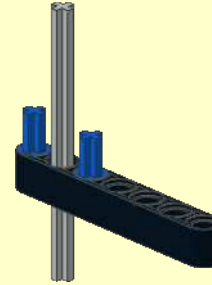
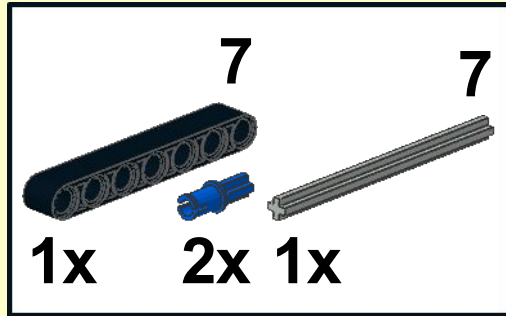

2

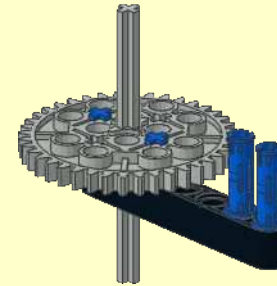
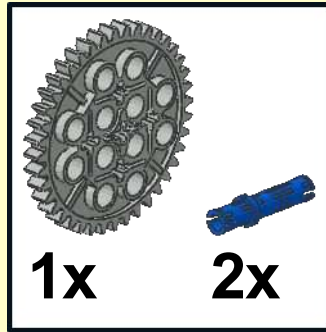

3

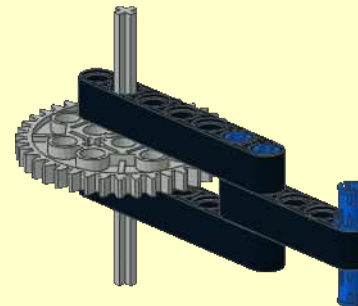
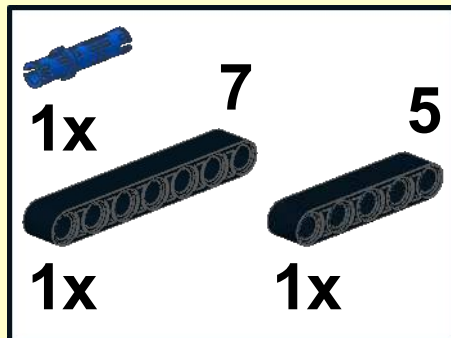

4

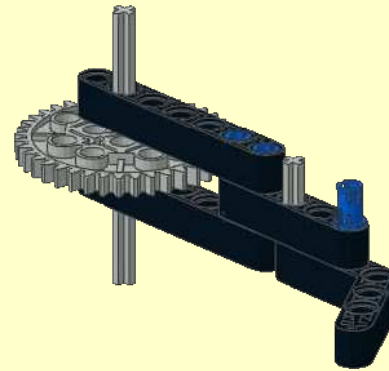
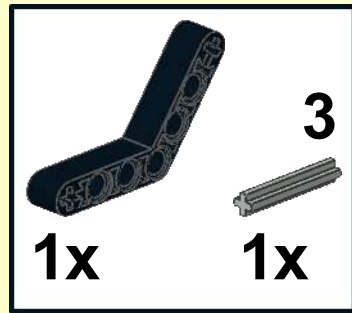

5

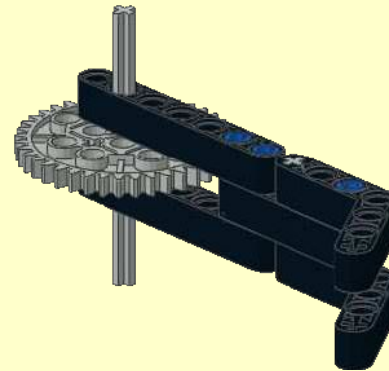

6

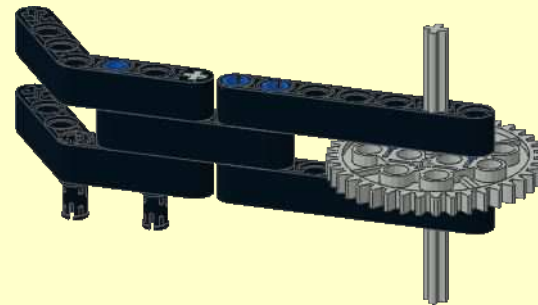

7

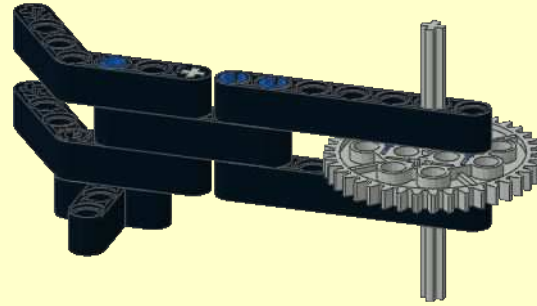

8

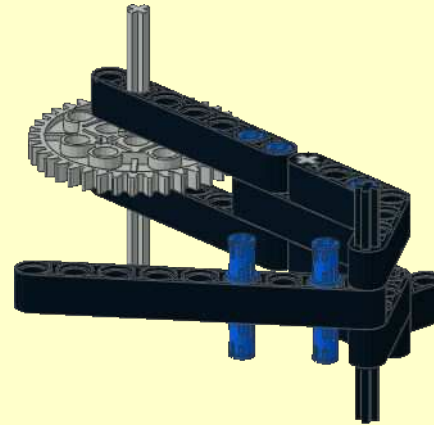
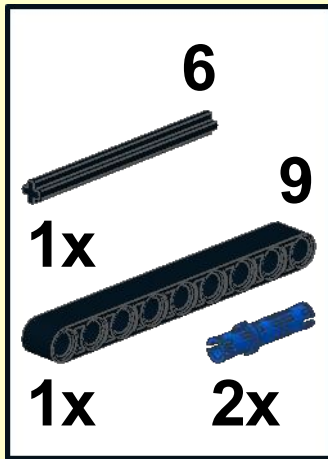

9

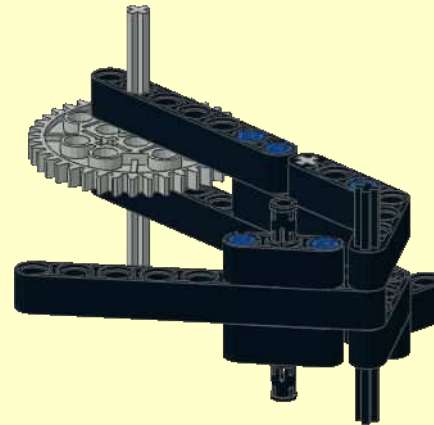

10

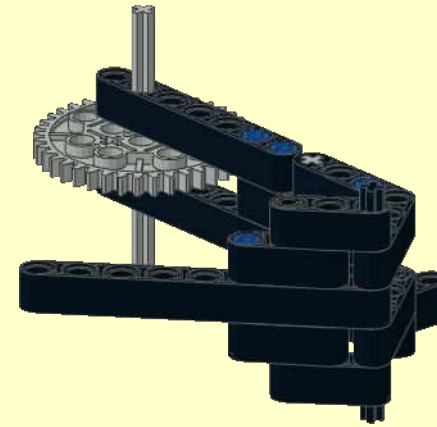

11

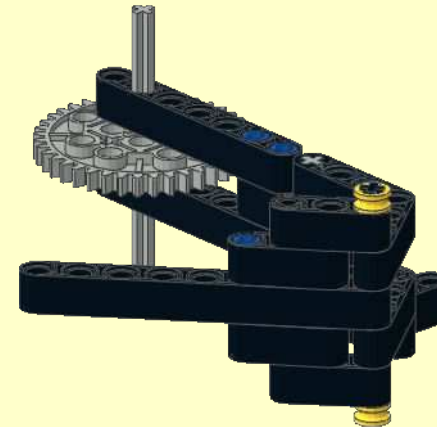

12

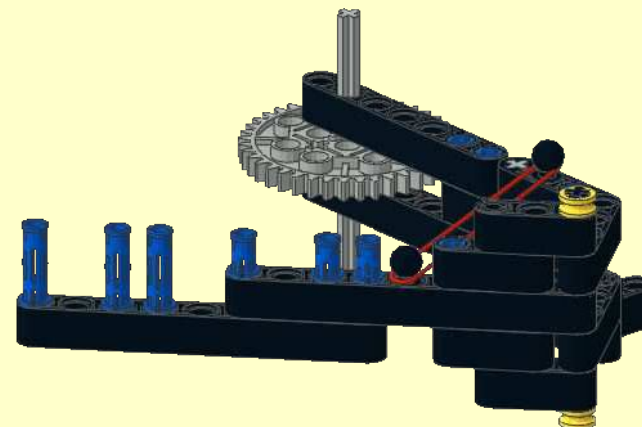
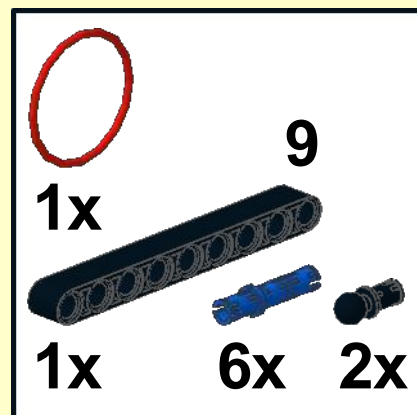

23

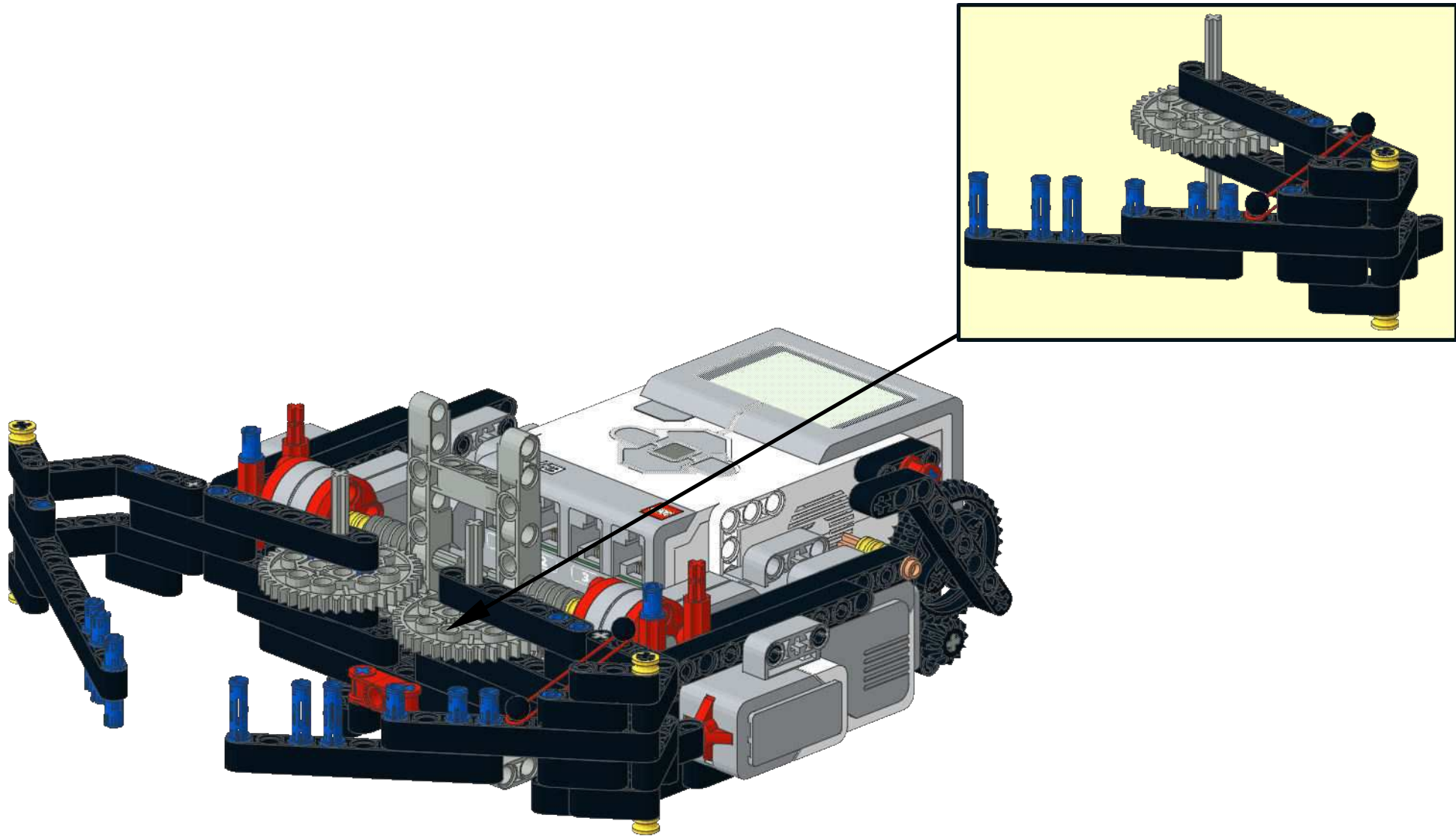



24

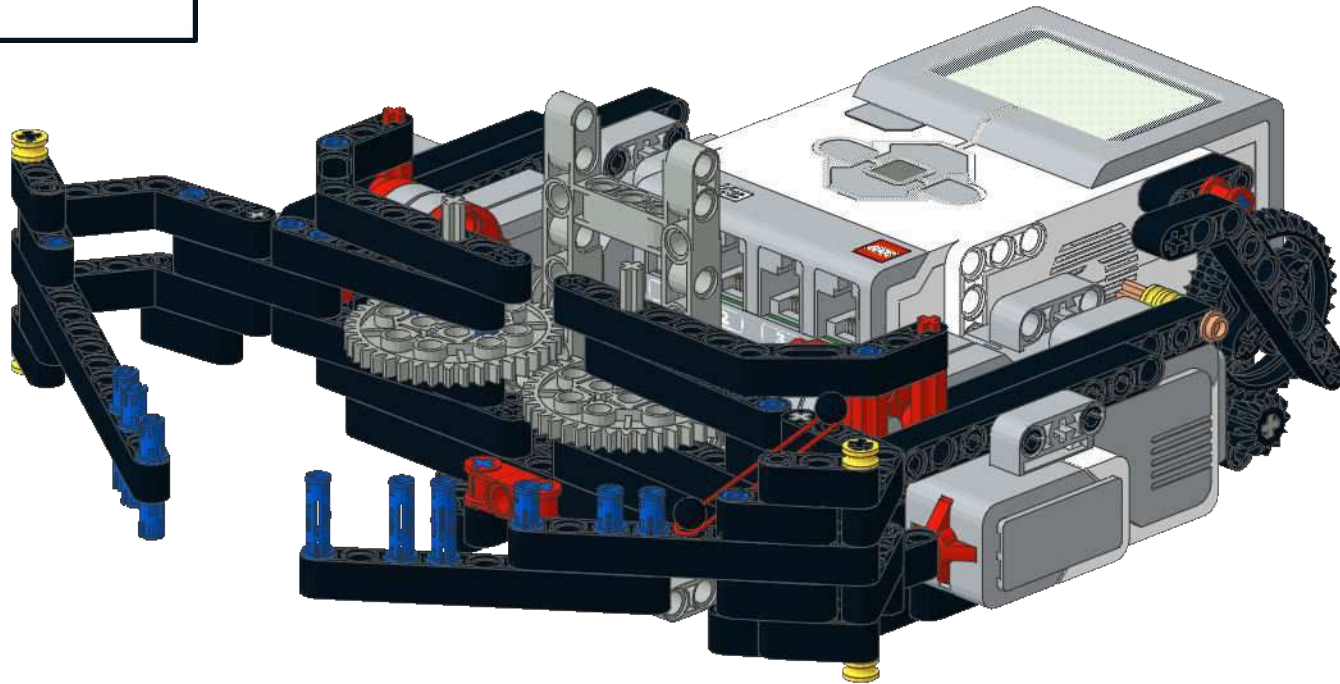
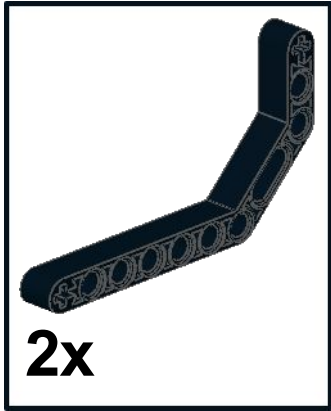

# 25

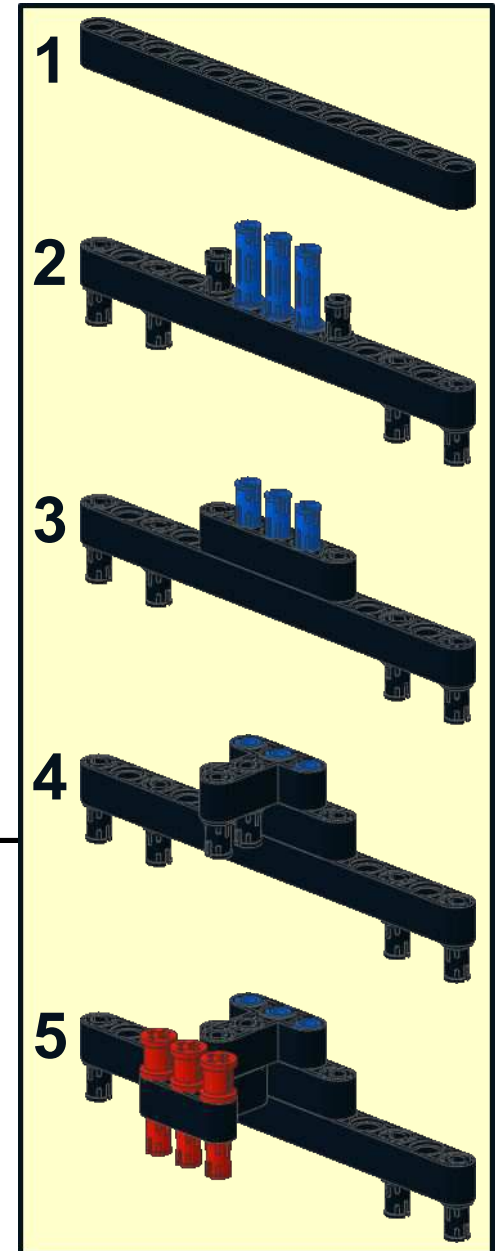
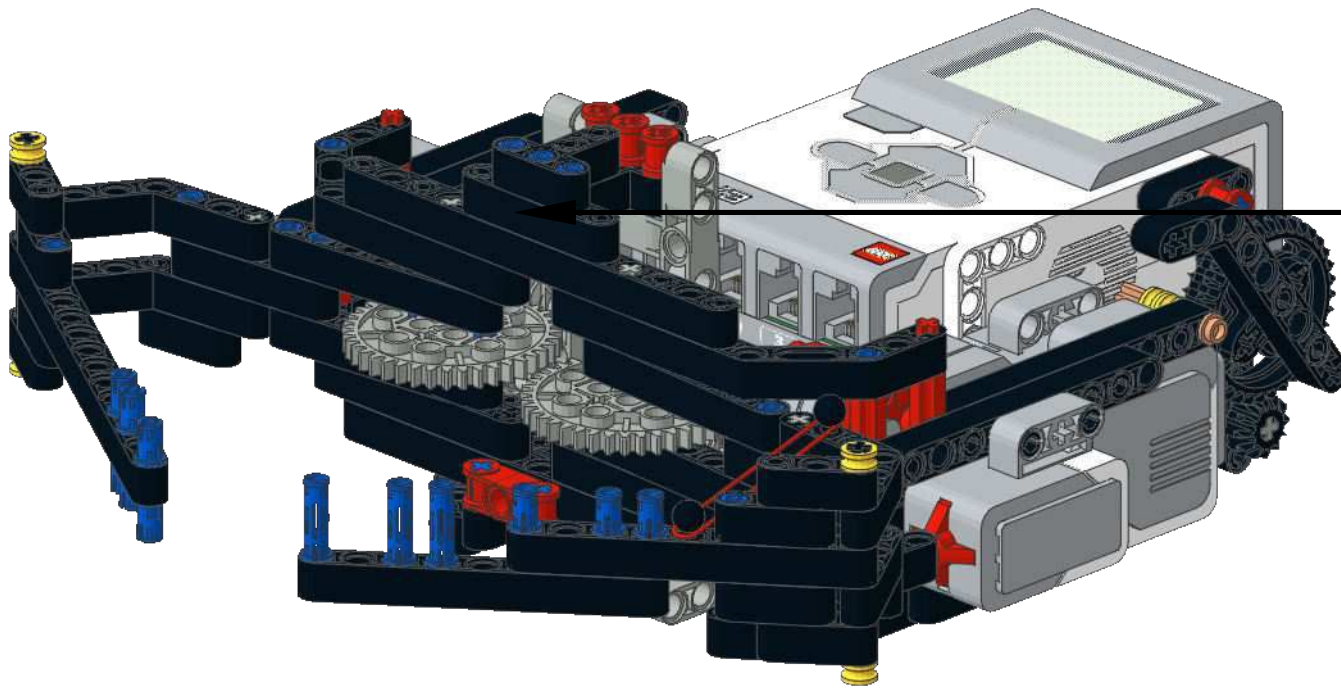
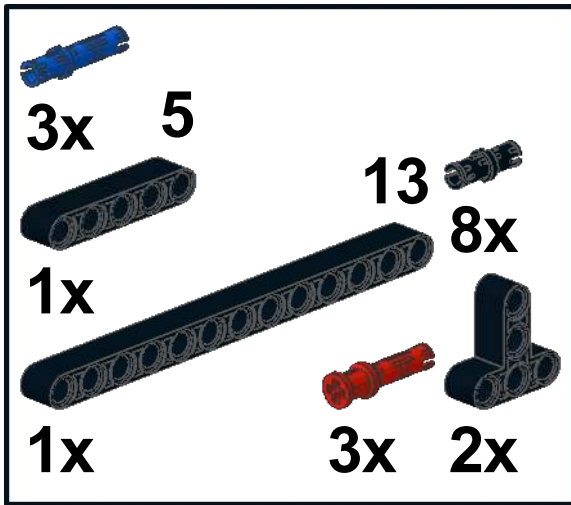

26

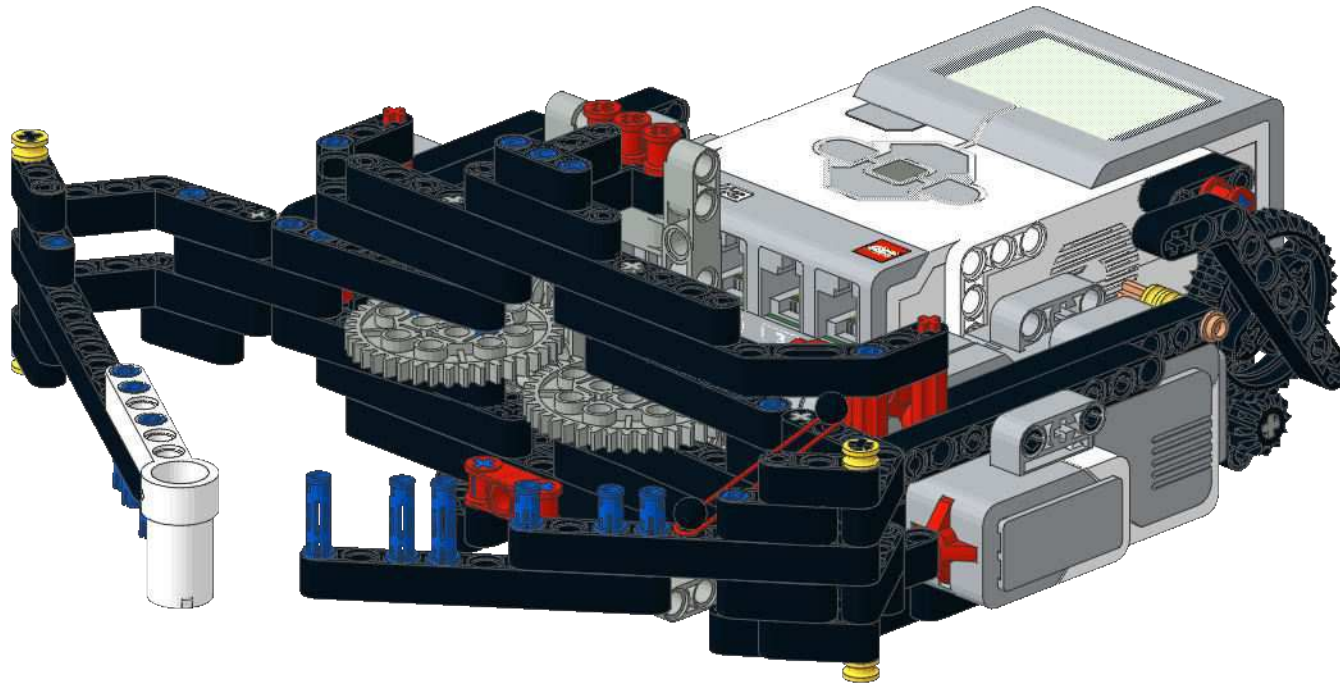
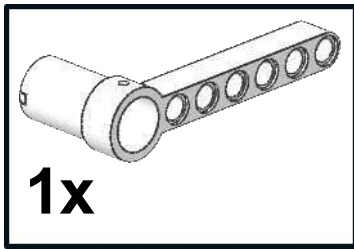

# 27

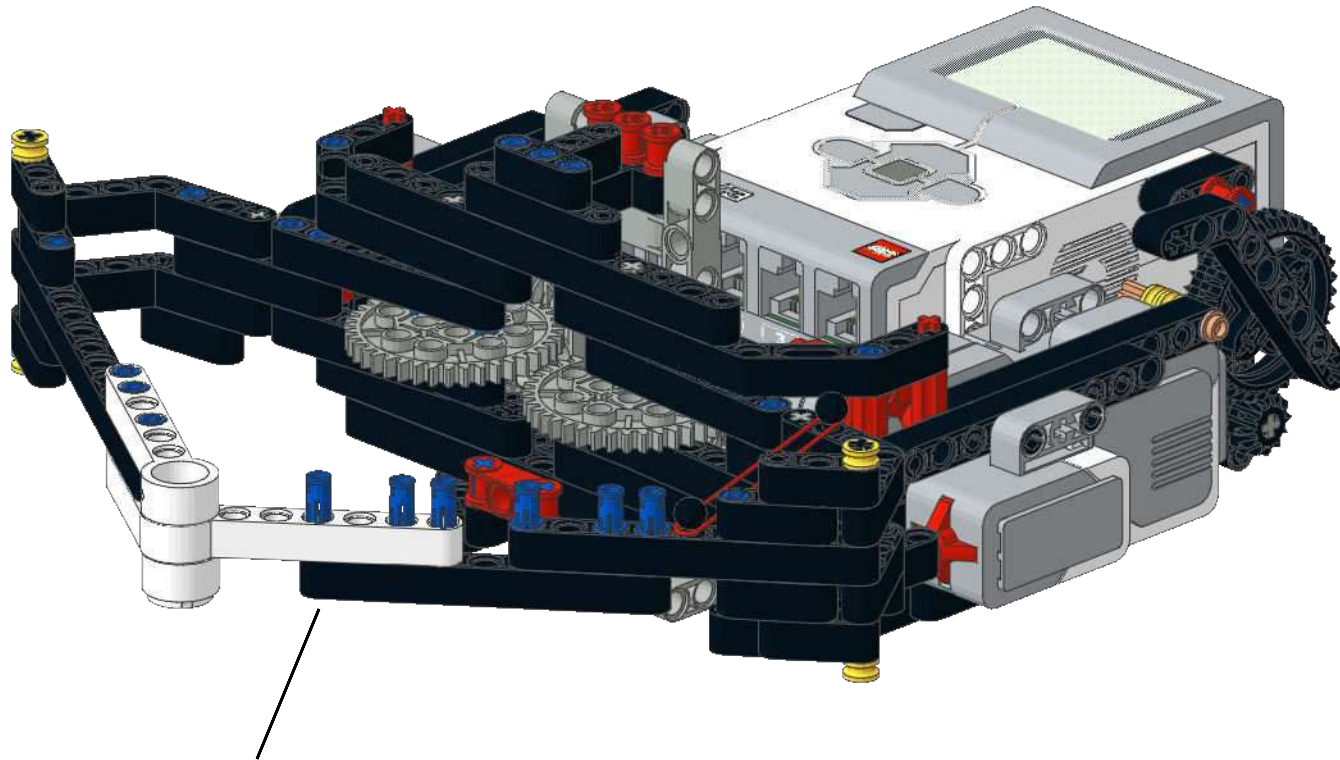
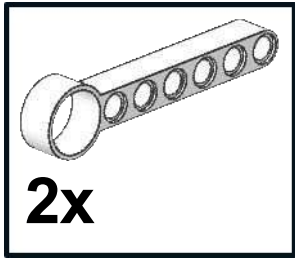

!! Warning !! Sizes of both arms must be equal. Shift the white part by one lego unit on the left.

28

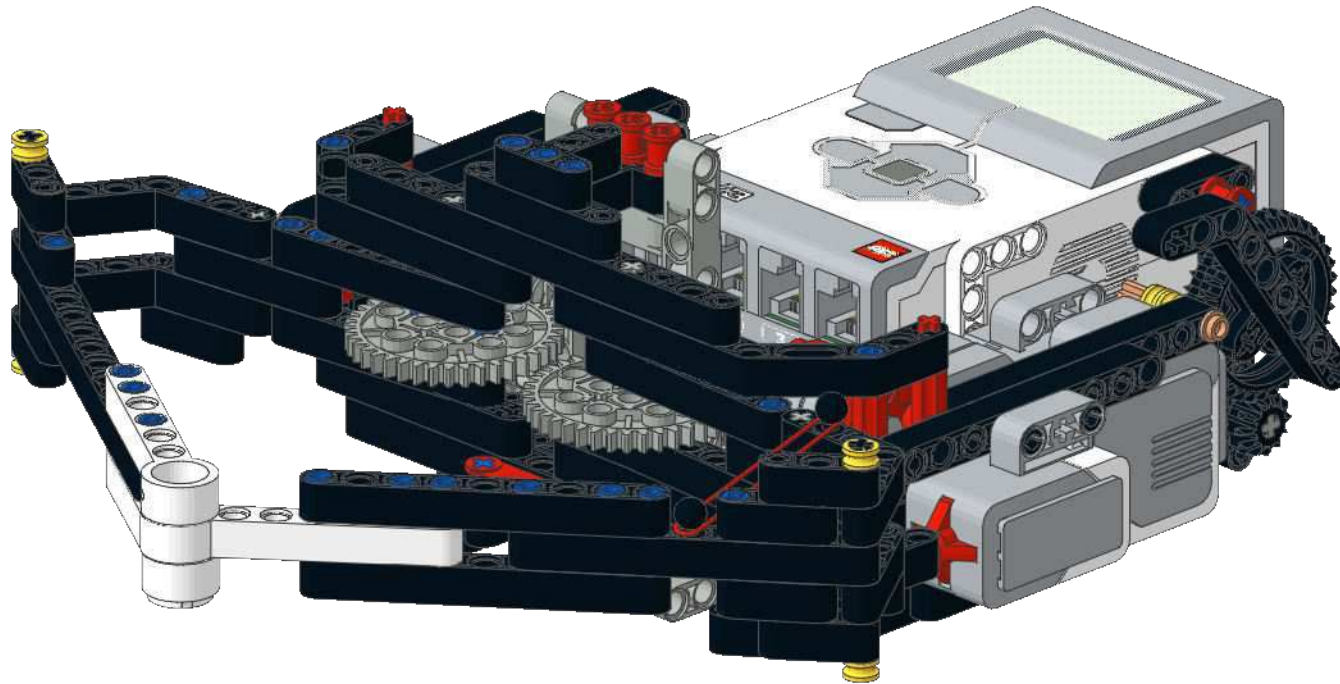
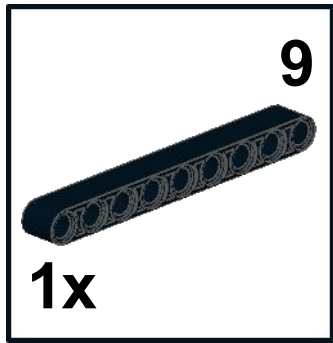

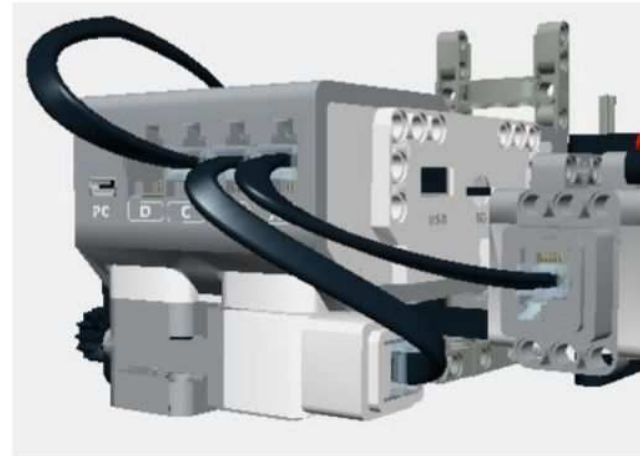

Connect left large motor to port C, right large motor to port A, and small motor to port B.  
Connect left touch sensor to port 2 and right touch sensor to port 3.